

LAUNCHER & HORIZONTAL DRIVE MOTORS

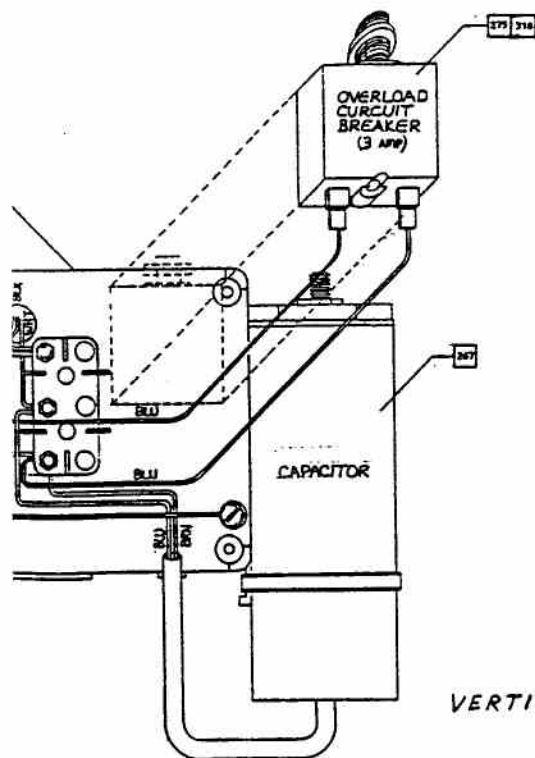

VERTICAL DRIVE MOTOR

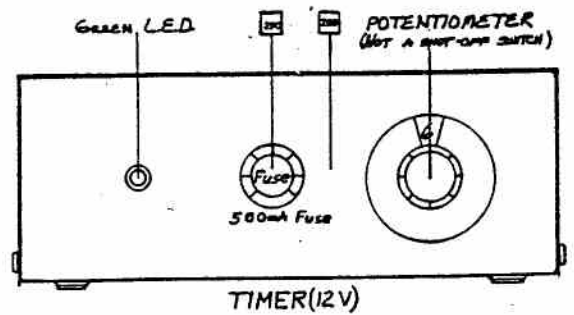

TIMER (12V)

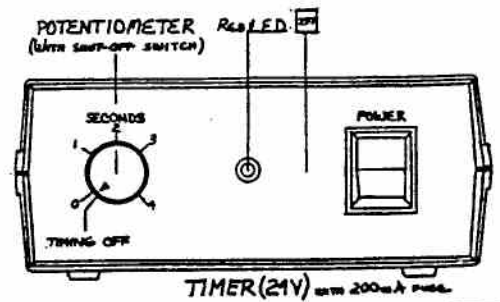

TIMER (24V) WITH 200mA FUSE

DESIGN: None	DATE: 7-5-87	NUMBER OF PAGES: 7
ELECTRICAL BOXES		
By: Clay Target Enterprises		7

REVISED: 8-4-88

**INSTALLATION AND OPERATING  
GUIDE**

**FOR BEOMAT MT400, MJT400, 700.**

# WARNING

ANY CLAY TARGET LAUNCHER REGARDLESS OF MANUFACTURE, BY THE NATURE OF ITS PURPOSE, CREATES A CERTAIN HAZARD WHERE THE OWNER/USER MUST PROVIDE FOR THE SAFE OPERATION OF SUCH UNIT AT HIS/HER/THEIR OWN EXPENSE AND RESPONSIBILITY.

DO NOT INSTALL THE LAUNCHER SO; THAT THE LAUNCHING ARM AREA IN THE FRONT, OR THE TARGET EXIT AREA AT THE RIGHT FRONT CORNER OF THE MACHINE IS UNPROTECTED. FURTHER, DO NOT ALLOW ENTRANCE TO THE HOUSE ON THE LEFT SIDE OF THE MACHINE, (THE MACHINE'S OWN LEFT SIDE).

IT IS REQUIRED THAT THE ELECTRICAL CONTROL BOX IS MOUNTED IN SUCH A LOCATION, USUALLY AT THE UPPER RIGHT FRONT CORNER OF THE TRAP HOUSE THAT THE LAUNCHER MAY BE RELEASED BY IT'S WIRE REMOTE SWITCH BEFORE ANYONE ENTERS THE HOUSE.

KEEP THE MACHINE AREA CLEAN AT ALL TIMES, REMOVE ALL EMPTY TARGET BOXES - IT GREATLY REDUCES SAFETY HAZARDS.

SHUT OFF POWER AND RELEASE THE LAUNCHER BEFORE PERFORMING ANY WORK WHATSOEVER IN THE HOUSE - WHEN LOADING TARGETS, OR MAKING ANY CHANGES ON THE LAUNCHER ITSELF.

VAENNGF01

## MJT 400 AND MT 400 Installation / Trap House

To ease the installation, remove the 4 bolts in the magazine center, (do not remove the circlip) and lift the magazine straight off the launcher, re-assemble in reverse order. Before installing the Beomat launcher, please remove the existing Winchester plank, it will not be needed with this machine. Based on the existing trap house, built as per the old Winchester specifications, the MT, or MJT400 will install onto the pier as per the dotted line. Please note that the base of the machine will be offset about 3 - 5° to the right. While the weight distribution of the machine is such that the launcher may be bolted onto the pier as is, additional support under the right side of the base is recommended. The red line on the machine base should correspond with the centerline of the house. It is recommended that the entrance to the trap house be on machines own right side, since the launching arm swings out on the machines own left side. It is also recommended that the control box, as seen on the opposite page, be fastened onto the trap house wall in the upper right side corner of the house as indicated by the dotted line. This provides easy and safe access to the safe release toggle switch, before entering the trap house. Stay clear of the house opening when releasing the machine.

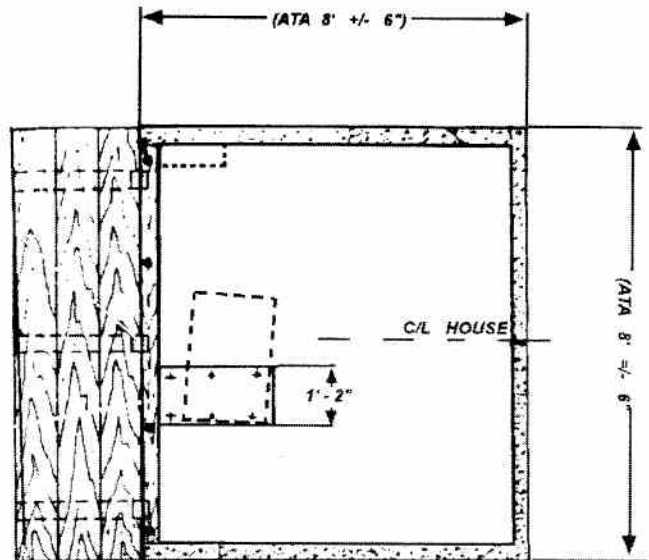

## Machine Installation

Shown here is the picture of the machine base with its red line across, this line should reasonably well correspond with the centerline of the house. The diagonal line in front of the turntable is your guide to set the machine to throw a target straight ahead. When the leading edge of the turn table is parallel with this line, the machine will throw a target approximately center field. The connecting rod shown will change the angle of spread, or width of the field. There are six hole positions on the turntable, the first hole at the tip of the table would be No. 1 The angle of Spread as follows;

- |                   |                   |
|-------------------|-------------------|
| #1, = approx. 32° | #2 = approx. 38°  |
| #3, = approx. 45° | #4 = approx. 60°  |
| #5, = approx. 75° | #6 = approx. 90°. |

The rod may also be used as a windage adjustment in that the rod is threaded, and thus the rod end may be adjusted to compensate for cross winds on the field.

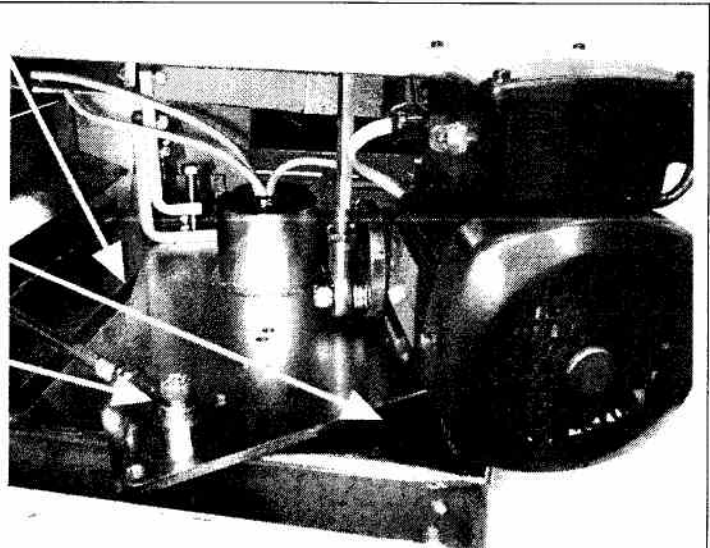

## Installation setup / target trajectory adjustments.

With the machine temporarily fastened on the pier, the **launching arm guard** and the launching arm installed. You having read all pages in this small booklet, and familiarized yourself with the operation of this new launcher. Please load a small number of targets in each magazine position and proceed as follows. To find the exact dispersion of targets on the field, stop the horizontal oscillation by turning off the switch in the machines left most position. Test fire a couple of targets and note the target path in reference to the left field marker, repeat the same procedures to the right side of the field, adjust by turning the entire launcher on the pier as needed. Repeat this procedures until the targets are thrown an equal distance from the field markers. Then secure the launcher to the pier. PLEASE CONDUCT ALL OPERATIONS SAFELY.

The adjustment for a level target flight is located on the inside of the bracket shown, loosen the two fasteners and adjust the vertical bolt until level flight is obtained, tighten the fasteners.

The length of the vertical connecting rod may be adjusted to change the entire "vertical window" up or down as required at your location.

A fine-tuning of the target height in stationary mode can be done by turning the knurled knob at the end of the vertical motor. --- For the MJT400, a turnbuckle will provide the vertical setting.

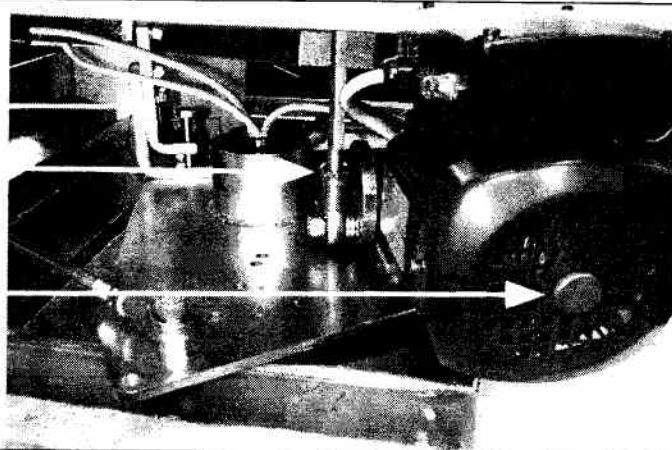

## Electrical Controls/connections.

The Beomat MT or MJT400 are equipped with a wire remote control box allowing for safe operation from the outside of the trap house.

The toggle switch at the end of box must be on for normal operation together with the launcher switch on the box. It then serves as a safe release switch in its momentary on position before the launcher switch is turned off.

The center switch operates the horizontal oscillations, and the right side switch (for MT-models) provides the vertical oscillation.

A midget twist lock receptacle at the end of the box is for the pull cord.

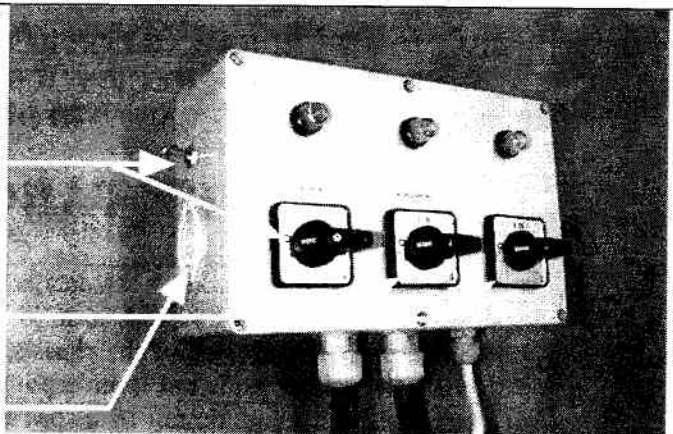

## Installation setup / spring tension adjustment.

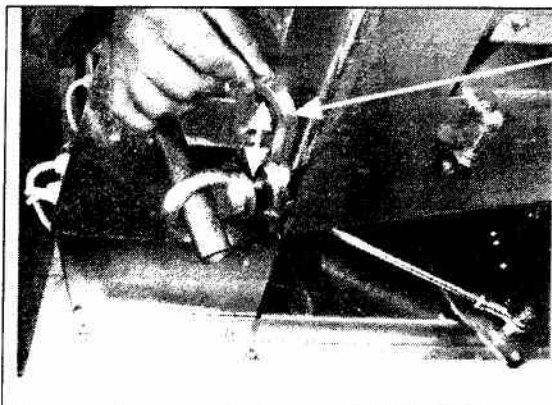

A spacer system is utilized for the changing of the spring tension, (changing of target throwing distance). Two different systems for setting the target flight distance may be used. ONE, the main spring is installed without pre-load, and the spacers may be used to obtain the desired distance with the spring as is. TWO, that the lock nut at the end of the spring be loosened and by turning the eyelet on the outside of the machine clockwise, thus pre-loading the spring. When the desired throwing distance is obtained, tighten the lock nut and use the spacer system for quick changes of more demanding games. The thick spacer will increase the target flight distance by about 10 yards and the other spacers in descending order down to 1 yard.

# ADJUSTMENT GUIDE

**YOUR BEOMAT LAUNCHER HAS UNDERGONE COMPLETE PRE-DELIVERY SERVICE, AND SHOULD NOT REQUIRE ANY OTHER ADJUSTMENTS THAN THE SETUP PROCEDURES AS DESCRIBED ON THE PREVIOUS PAGES. IF THE LAUNCHER IS NOT PERFORMING PROPERLY AFTER INSTALLATION, (THE MACHINE MAY HAVE BEEN EXPOSED TO FREIGHT DAMAGE). IF SO, PLEASE CALL BEOMAT OF AMERICA IMMEDIATELY, AT ANY TIME, (408) 379-4829. IF AFTER BUSINESS HOURS PLEASE REMAIN ON THE LINE, THE CALL WILL TRANSFER TO A SELECTED TECHNICAL SUPPORT PHONE AFTER SEVEN RING SIGNALS.**

## **IF YOUR LAUNCHER IS NOT PERFORMING CORRECTLY, BEFORE ANY ADJUSTMENTS ARE DONE, PLEASE CHECK THE FOLLOWING:**

- A. Confirm that the launching arm is **STRAIGHT**, remove the arm and visually inspect the same (after some time of use, a slight "banana shape" in the working direction is normal and acceptable). However, if the arm is bent either up or down, it will severely effect the target flight, or cause target breakage. In such a case, replace the arm before checking further. If you think the arm needs adjustment please see next page.
- B. Verify that the elevator is adjusted correctly, i.e. a clearance between the highest point of the elevator and the bottom rim of the target - (in its ready to fire position), of at least 1/4" or more.
- C. Confirm that the target retainer brush is "holding" the target close to the launching arm (a distance between the target and the launching arm of about a 1/4" is acceptable).

**THE FOLLOWING PICTURES AND INSTRUCTIONS WILL HELP YOU MAINTAIN YOUR BEOMAT LAUNCHER. PLEASE CHECK YOUR LAUNCHER PERIODICALLY. PLEASE KEEP THE LAUNCHER CLEAN, AND DO NOT LOAD BROKEN TARGETS.**

## **THE TARGET NEST**

The birds view of the target nest shows you all the details for an excellent target performance. The launching arm (# 1), should be roughly parallel with the left side of the chassis, or as shown in this drawing. The target guide rail is an important part of the target performance. This guide rail (# 2) has had various lengths through the years, and is now at the exact length of six inches. Please note the exact position of the guide rail. (Should you have machines of an earlier model, it will be a great advantage to arrange the target nest to these exact specifications together with a new brush. If the guide rail is longer than 6 inches, it is important that it be shortened to that length before adjusting it to the position shown here). We have recently improved the nest brush itself (# 3) in order to have the optimum performance, and the brush is now mounted directly onto the magazine table. (The brush in this picture is equipped with a bracket (# 4), and as such applies to earlier style machines). The brush position is essentially the same regardless of mounting, should the brush require replacement, detailed instructions are furnished with the brush.

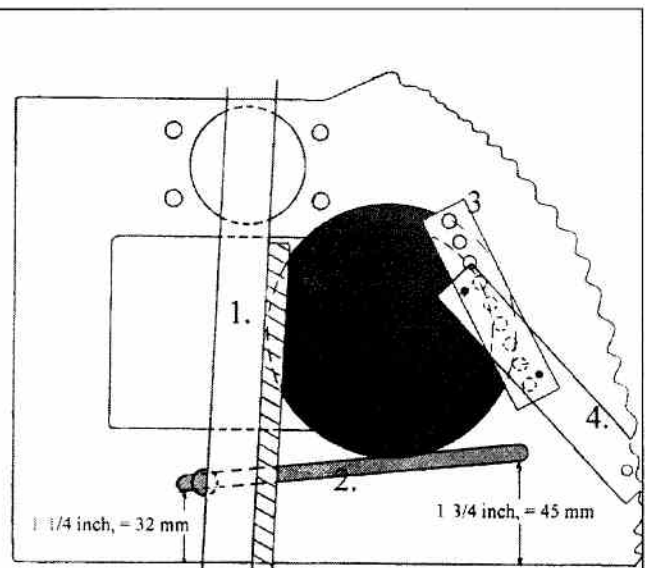

# CORRECT LAUNCHING ARM ADJUSTMENT PROCEDURE.

## VISUAL CHECK ILLUSTRATION

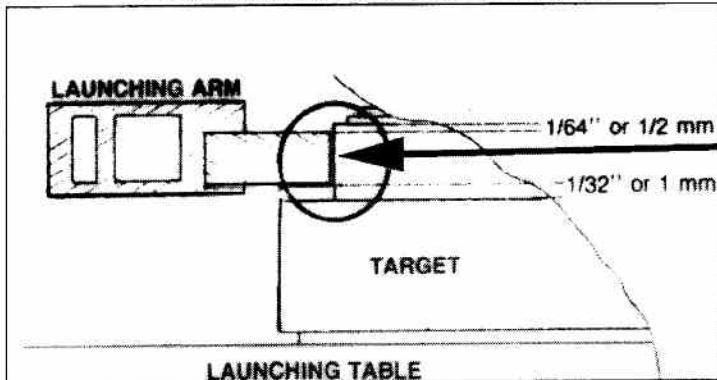

Check the launching arm adjustment with the launcher in the cocked position, viewing the arm and the target from the rear of the machine (refer to illustration at left).

Then shut off power and release the launcher by its toggle switch at the square receptacle box on the cord. (Or, if not existing, it is perfectly safe to release the arm using your index finger behind the tip of the arm, pushing it to start after the power has been shut off)

## ADJUSTMENT ILLUSTRATION

Procedures, (this view from the launchers own left side). Please note the position of the launching arm carrier. Refer to illustration above, before any adjustments are made. Proceed with the adjustment, use a 6 mm Allen tool to loosen bolt (indicated by arrow in illustration at right), about 1/2 to 1 turn, while supporting the launching arm with your left hand. Then lightly pry the launching arm carrier up or down on the main shaft with a medium size screwdriver, "walking" it to the desired position on the shaft. Repeat the above steps until the correct adjustment is obtained. Tighten the retainer bolt to **17-20 Lb. Ft.** (or 25-30 NM or 2.2-2.6 Kpm).

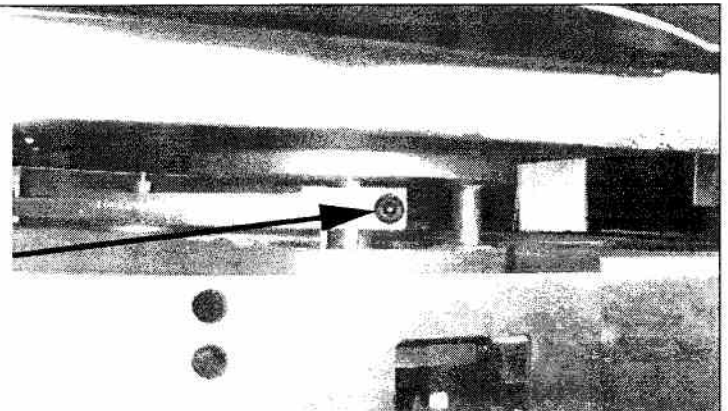

## MICRO SWITCH ADJUSTMENT

MAY BE ONE OF THE MOST COMMON CORRECTIONS ON THE MACHINE. FOR INSTANCE, IF THE MACHINE SHOULD START RELEASING TARGETS ON ITS OWN, AN ADJUSTMENT OF THE SWITCH TO THE LEFT, OR DOWNWARDS MAY BE A CORRECT SOLUTION.

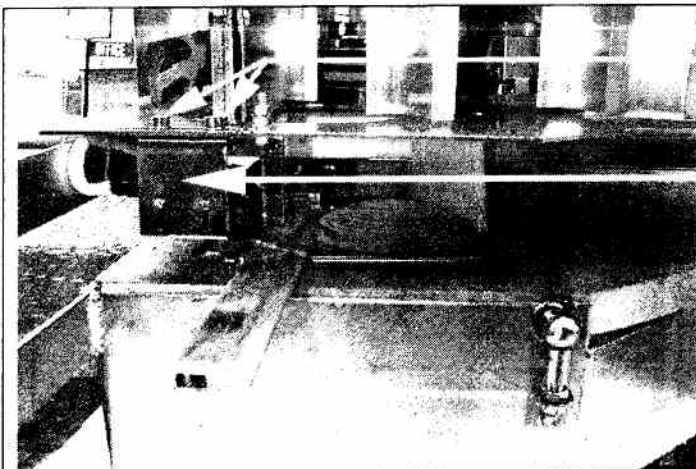

The micro switch is controlling the re-cocking function of the launcher, and is activated by the launching arm. To adjust the height of the switch, simply loosen the two slot mounted screws (shown) and slide the entire switch body up or down. Another adjustment, (not visible in this picture) is that the entire bracket may be moved in the slotted mounting holes at top of bracket, allowing the switch assembly to be moved left or right. NOTE, the ideal position as shown, with the launching arm parallel with the left side of the chassis and the leading edge of the arm flush with the tip of the switch lever.

## Adjustment of the back lash brake.

In order to eliminate vibrations, a brake band with a one-way clutch is installed on the launching arm shaft. Tightening of the adjusting bolt, turning clockwise, will increase the brake efficiency. Please adjust so that the launching arm stops without vibrations "on the corner of the chassis." If a moderate tightening of this bolt does not have the desired effect, the sprague within the band may be faulty or worn.

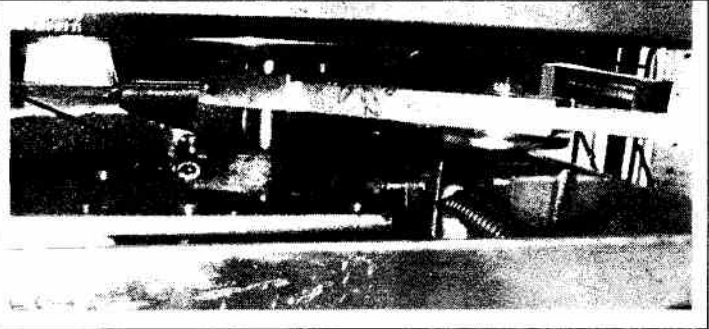

## Elevator clearance.

The only reason for the elevator to require an adjustment would be if there is a lot of broken targets loaded in the machine. The result is that the elevator must cut through the target pieces, which in turn may cause a slight bend in the parallel arm assembly, thus, necessitating adjustment. The machine itself will not break any targets unless it is severely out of adjustment. (under severe conditions it may be necessary to either straighten or replace the parallel arm assembly).

The elevator should be checked with the power shut off and the machine released manually, i.e. not by the electrical switch, since the elevator will be moving upwards immediately when released by the electrical switch.

The distance from the highest point of the elevator to the bottom rim of the target should be a minimum of a  $\frac{1}{4}$  inch, as per illustration on the right.

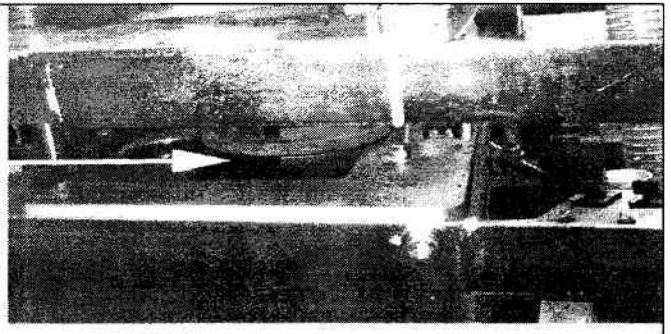

## Elevator height adjustment.

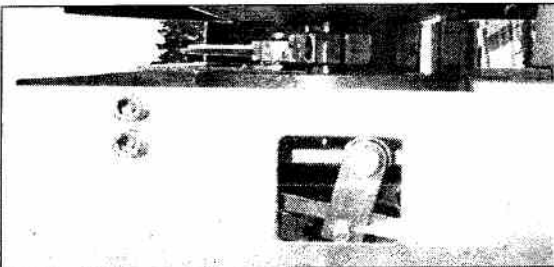

Adjustment of the elevator, is done by loosening the small bolt, as shown, at the bearing riser on the parallel arm assembly. Then by sliding the bearing riser for or aft you will be changing the height of the elevator. (Again, the machine must be released manually in order to have the elevator position correct).

And of course, as always, --- the power must be shut off and the launcher released before any adjustments are made.

## Target separating knife

A target separating knife is installed on your Beomat machine. The knife is installed in a reversed position for the reason that it must be adjusted individually for every manufacture of targets. When activated, loosen the nut at the top, reverse the knife and use the installed washers to adjust the height. It may be necessary to bend the knife slightly up or down in order to very precisely adjust the knife. The knife will perform excellently with wet targets, but bear in mind, if not adjusted properly it will cause more harm than good.

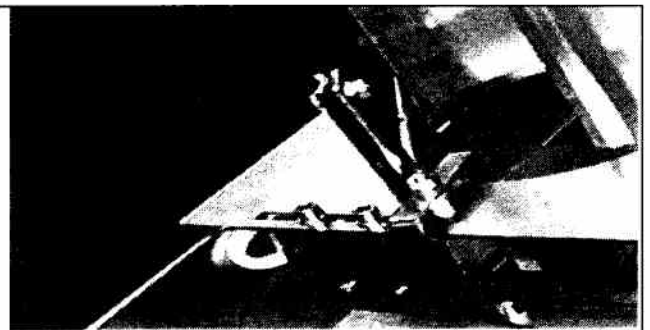



## Drive belt adjustment

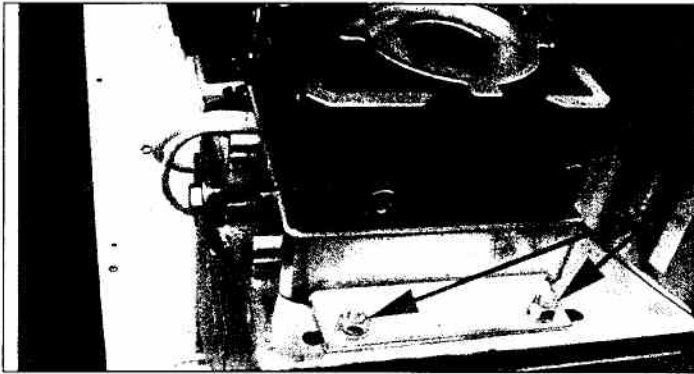

A pair of regular V-belts, are utilized between the reduction gear and the launcher main shaft. After some time, a year or two, it may be necessary to tighten the belts slightly. This is done by loosening the two fasteners as shown, about one turn or at the most a turn and a half, then by tightening the belt tension bolt, shown, about one full turn. (It should be understood that too great a belt tension will put unnecessary pressure on the drive mechanism). Then re-tighten the two fasteners at the gear bracket.

## Leaf spring

A leaf spring is installed to provide an "ease down" of the target stack. Adjustment is normally not required, however, if the spring should need replacement, or come out of position, it should be adjusted so; that when the magazine is filled with targets and after delivering one target to the elevator, the full stack of targets will ease down as the magazine starts indexing again.



## Launching table fasteners



Never adjust the launching table fasteners. They have been adjusted once and for all. **ANY TAMPERING WITH, OR ADJUSTMENT OF THE SAME, WILL INVALIDATE YOUR WARRANTY.**

### INDEX

ADJUSTMENT GUIDE.....	4.
BACK LASH BRAKE ADJUST.....	6.
DRIVE BELT ADJUST.....	7.
ELECTRICAL CONNECTIONS.....	3.
ELEVATOR CLEARANCE / ADJUST.....	6.
LAUNCHING ARM ADJUST.....	5.
LEAF SPRING .....	7.
MICRO SWITCH ADJUST.....	5.
TRAP INSTALLATION.....	2.
SPRING TENSION, LENGTH OF THROW.....	3.
TARGET NEST.....	4.
TARGET SEPARATING KNIFE.....	6.
TARGET TRAJECTORY SETUP.....	2-3.
WARNING PAGE.....	1.

**INSTALLATION AND OPERATING  
GUIDE**

**FOR BEOMAT MS 400, MS 700, MS 900.**

# WARNING

ANY CLAY TARGET LAUNCHER REGARDLESS OF MANUFACTURE, BY THE NATURE OF ITS PURPOSE, CREATES A CERTAIN HAZARD WHERE THE OWNER/USER MUST PROVIDE FOR THE SAFE OPERATION OF SUCH UNIT AT HIS/HER/THEIR OWN EXPENSE AND RESPONSIBILITY.

DO NOT INSTALL THE LAUNCHER SO; THAT THE LAUNCHING ARM AREA IN THE FRONT, OR THE TARGET EXIT AREA AT THE RIGHT FRONT CORNER OF THE MACHINE IS UNPROTECTED. FURTHER, DO NOT ALLOW ENTRANCE TO THE HOUSE ON THE LEFT SIDE OF THE MACHINE, (THE MACHINE'S OWN LEFT SIDE).

IT IS REQUIRED THAT THE ELECTRICAL HANDY BOX IS MOUNTED IN SUCH A LOCATION THAT THE LAUNCHER MAY BE RELEASED BY IT'S WIRE REMOTE SWITCH BEFORE ANYONE ENTERS THE HOUSE.

KEEP THE MACHINE AREA CLEAN AT ALL TIMES, REMOVE ALL EMPTY TARGET BOXES - IT GREATLY REDUCES SAFETY HAZARDS.

SHUT OFF POWER AND RELEASE THE LAUNCHER BEFORE PERFORMING ANY WORK WHATSOEVER IN THE HOUSE - WHEN LOADING TARGETS, OR MAKING ANY CHANGES ON THE LAUNCHER ITSELF.

WARNING PAGE

# Installation of your Beomat Skeet machines.

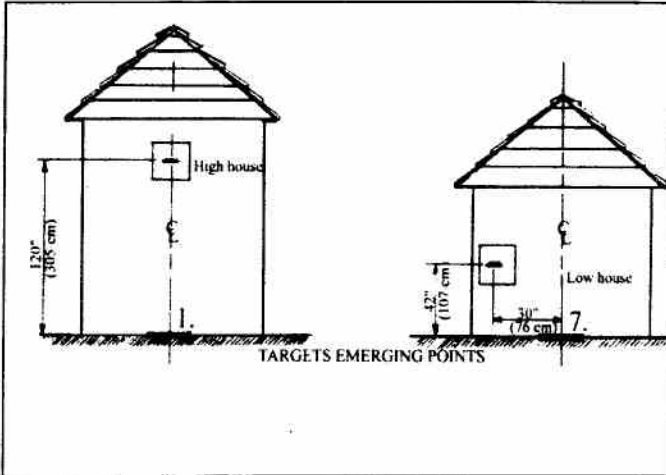

**High house;** determine the exact position of the targets emerging point in relation to shooting station # 1. The base chord of the field should correspond with the centerline of shooting station 1. The target should be emerging on the centerline of station 1.

**Low house:** Again, determine the exact position of the target at its emerging point in relation to shooting station # 7. The base chord of the field should correspond with the centerline of station 7. Set reference marks for the targets emerging point at the bottom and on one side of each "window", or use electrical/masking tape to set a "cross hair" across the window, this gives a very exact point to measure from. Measurements are the same for American as well as International skeet.

Before attempting to install the machines into respective house, the magazines must be removed by removing the 4 bolts in the center of the magazine, then lift the magazine straight off the launcher. (Do not remove the lock ring at the shaft), assemble in reverse order.

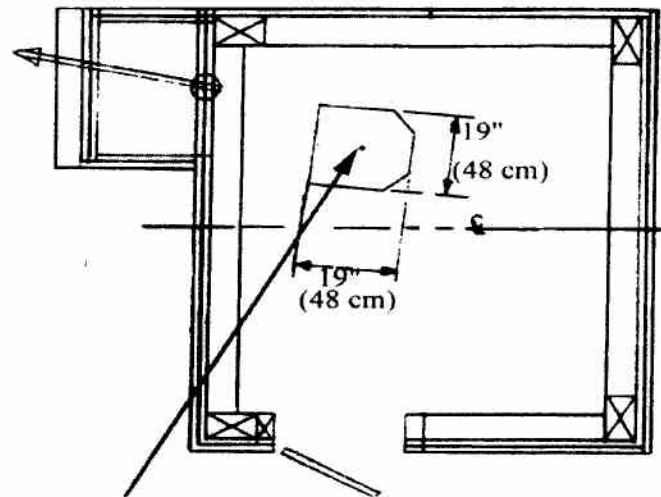
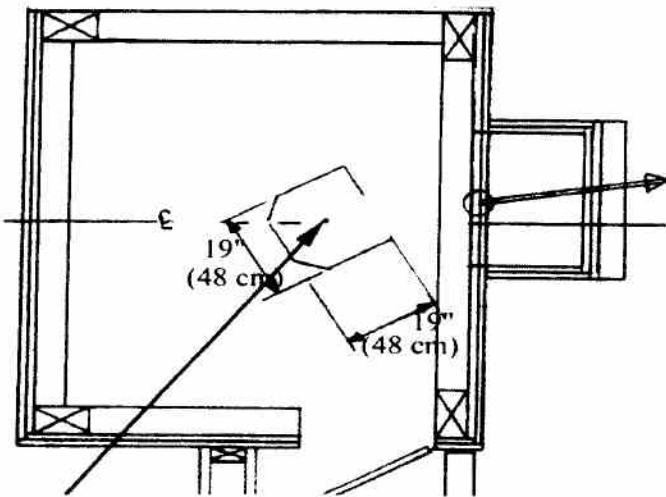

**High House.** By using the now established target emerging point, and the center hole (pivot hole) in the base plate of the machine, the following measurements will apply. The center hole (pivot) in the base plate of the machine is to be located 16" (41 cm) below the targets emerging point. The distance from the front wall to the pivot point in the base should be about 24" (61 cm). And, 5" (13 cm) offset to the (outside of the field), or left of the imaginary target trajectory line as seen from behind the machine. If the old Winchester pier is used, it will be necessary to increase the height of this pier about 4". This may be done, by using 2 pieces of 4" x 14" x 30" planks positioned across the old pier. It is important that the base plates are in level. Base plate dimension is 19" x 19" for both machines.

**Low House.** The base plate pivot hole must be located 21" (53 cm) below the targets emerging point. The pivot hole 24" (61 cm) setback from the front wall, and 5" (13 cm) offset to the (inside of the field), or left of the imaginary trajectory line as seen from behind the machine.

**High house & Low house.** Before bolting the machine to the pier, install the launching arm guard, the magazine and the launching arm. Connect the wiring as per wiring instructions on the next page. Load a small amount of targets and test fire the machine to determine that the emerging point is correct, make minor adjustments by moving the machine side to side, forward or aft, until a satisfactory result has been achieved. The turnbuckle at the base is to change the elevation of the target. Make sure that these procedures are conducted safely, with the launcher released when adjustments are made.

## Electrical compatibility/connections.

Standard, non-oscillating single target launchers, MS400, 700, 900, are equipped with a 120 volt AC release system for compatibility with your existing Winchester/Ohlin installation. The electrical connections are identical to your Winchester/Ohlin machines/field wiring. The machines are equipped with a switch box, with an ON-OFF-Momentary function. The momentary function provides a safe release for the machines. The electrical connections in your skeet house should be color for color; black = HOT (or face), white = NEUTRAL (or 0), green = GROUND (or earth), red = RELEASE. (Please note, the wiring is European color, but with colored sleeves corresponding to US standard).

NO PICTURE AVAILABLE

## **Installation setup / target trajectory adjustments.**

There are three adjustments for the target trajectory. One, for the leveling of the target; the right side support leg is adjustable, please note the two lock bolts and a height adjustment bolt which may be adjusted to accommodate any specific target for a perfectly flat trajectory. The vertical adjustment (setting the target height), is simply done by the turnbuckle. The next adjustment is providing a horizontal movement. Once the target path has been established, a minor side to side adjustment may be done by loosening the bolt at the base plate slot, then turning the machine to either side for wind adjustment.

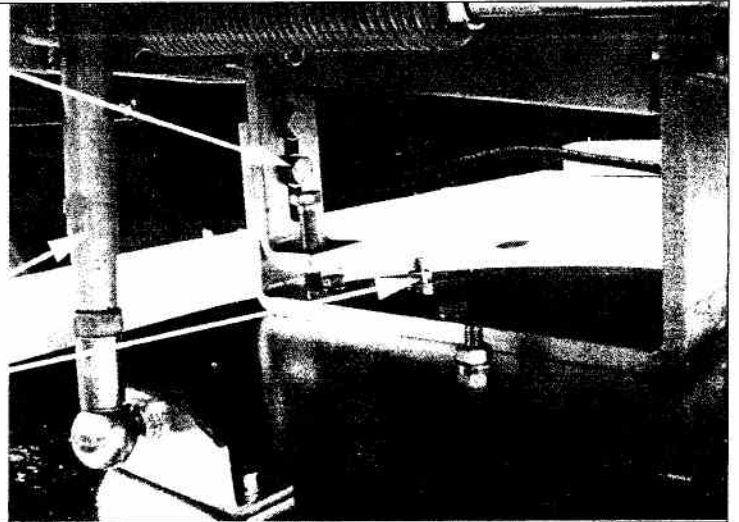

## **Installation setup / spring tension adjustment.**

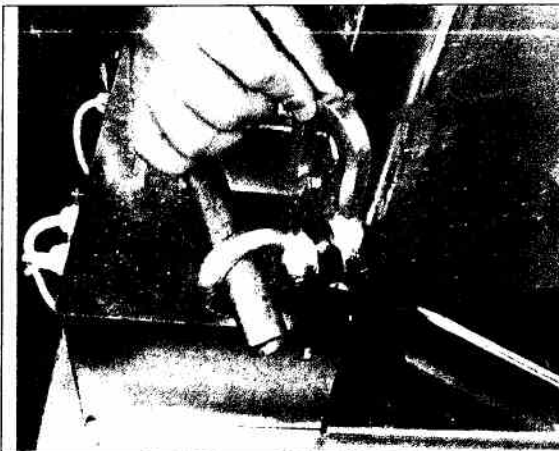

A spacer system is utilized for the changing of spring tension, (changing of target throwing distance). The spring is installed without pre-load, and two different systems for setting the target flight distance may be used. ONE, that the spacers may be used to obtain the distance desired with the spring as is. TWO, that the lock nut at the end of the spring be loosened and by turning the eyelet on the outside clockwise thus increasing the spring tension. When the desired distance is obtained, tighten the lock nut, and use the spacer system for quick changes of more demanding games. The thick spacer will increase the target flight distance by about 10 yards and the other spacers in descending order down to 1 yard.

# ADJUSTMENT GUIDE

**YOUR BEOMAT LAUNCHER HAS UNDERGONE COMPLETE PRE-DELIVERY SERVICE AND SHOULD NOT REQUIRE ANY ADJUSTMENTS WHATSOEVER AT THE TIME OF INSTALLATION. IF THE LAUNCHER IS NOT PERFORMING PROPERLY AFTER INSTALLATION, (THE MACHINE MAY HAVE BEEN EXPOSED TO FREIGHT DAMAGE). IF SO, PLEASE CALL BEOMAT OF AMERICA IMMEDIATELY, AND AT ANY TIME, (408) 379-4829. IF AFTER BUSINESS HOURS PLEASE REMAIN ON THE LINE, THE CALL WILL TRANSFER TO A SELECTED TECHNICAL SUPPORT PHONE AFTER SEVEN RING SIGNALS.**

## IF YOUR LAUNCHER IS NOT PERFORMING CORRECTLY, BEFORE ANY ADJUSTMENTS ARE DONE, PLEASE CHECK THE FOLLOWING:

- A. Confirm that the launching arm is **STRAIGHT**, remove the arm and visually inspect the same (after some time of use, a slight "banana shape" in the working direction is normal and acceptable). However, if the arm is bent either up or down, it will severely effect the target flight, or cause target breakage. In such a case, replace the arm before checking further. If you think the arm needs adjustment please see next page.
- B. Verify that the elevator is adjusted correctly, i.e. a clearance between the highest point of the elevator and the bottom rim of the target - (in its ready to fire position), of at least 1/4" or more.
- C. Confirm that the target retainer brush is "holding" the target close to the launching arm (a distance between the target and the launching arm of about a 1/4" is acceptable).

**THE FOLLOWING PICTURES AND INSTRUCTIONS WILL HELP YOU MAINTAIN YOUR BEOMAT LAUNCHER. PLEASE CHECK YOUR LAUNCHER PERIODICALLY. PLEASE KEEP THE LAUNCHER CLEAN, AND DO NOT LOAD BROKEN TARGETS.**

## THE TARGET NEST

The birds eye view of the target nest shows you all the details for an excellent target performance. The launching arm (# 1), should be roughly parallel with the left side of the chassis, or as shown in this drawing. The target guide rail is an important part of the target performance. This guide rail (# 2) has had various lengths through the years, and is now at the exact length of six inches. Please note the exact position of the guide rail. (Should you have machines of an earlier model, it will be a great advantage to arrange the target nest to these exact specifications together with a new brush. If the guide rail is longer than 6 inches, it is important that it be shortened to that length before adjusting it to the position shown here).

We have recently improved the nest brush itself (# 3) in order to have the optimum performance, and the brush is mounted directly onto the magazine table. (The brush in this picture is equipped with a bracket (# 4), and as such applies to earlier style machines). The brush position is essentially the same regardless of mounting, should the brush require replacement, detailed instructions are furnished with the brush.

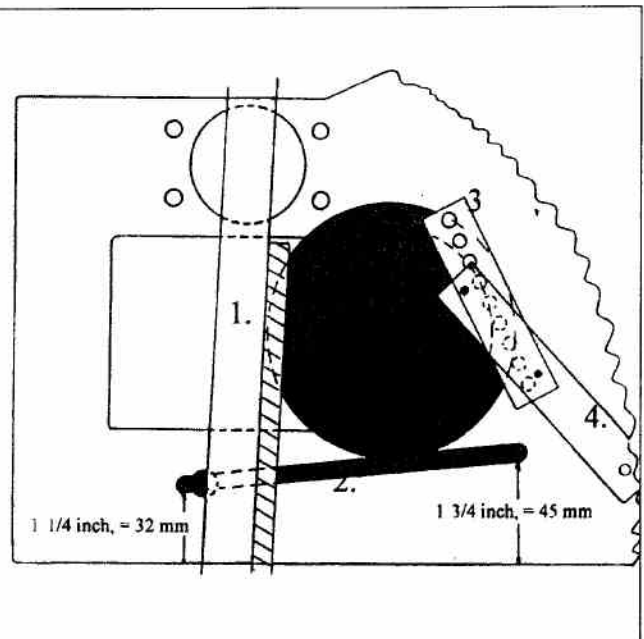

# CORRECT LAUNCHING ARM ADJUSTMENT PROCEDURE.

## VISUAL CHECK ILLUSTRATION

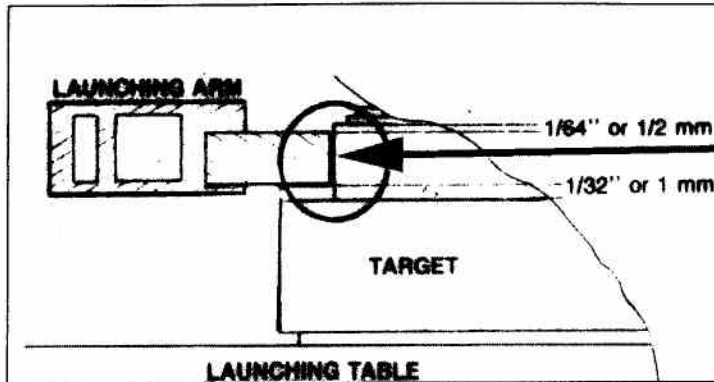

Check the launching arm adjustment with the launcher in the cocked position, viewing the arm and the target from the rear of the machine (refer to illustration at left).

Then shut off power and release the launcher by its toggle switch at the square receptacle box on the cord. (Or, if not existing, it is perfectly safe to release the arm using your index finger behind the tip of the arm, pushing it to start after the power has been shut off)

## ADJUSTMENT ILLUSTRATION

Procedures, (this view from the launchers own left side). Please note the position of the launching arm carrier. Refer to illustration above, before any adjustments are made. Proceed with the adjustment, use a 6 mm Allen tool to loosen bolt (indicated by arrow in illustration at right), about 1/2 to 1 turn, while supporting the launching arm with your left hand. Then lightly pry the launching arm carrier up or down on the main shaft with a medium size screwdriver, "walking" it to the desired position on the shaft. Repeat the above steps until the correct adjustment is obtained. Tighten the retainer bolt to **17-20 Lb. Ft.** (or 25-30 NM or 2.2-2.6 Kpm).

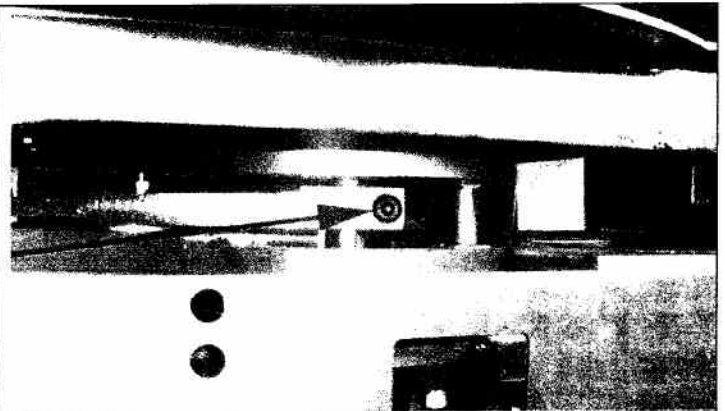

## MICRO SWITCH ADJUSTMENT

MAY BE ONE OF THE MOST COMMON CORRECTIONS ON THE MACHINE. FOR INSTANCE, IF THE MACHINE SHOULD START RELEASING TARGETS ON ITS OWN, AN ADJUSTMENT OF THE SWITCH TO THE LEFT, OR DOWNWARDS MAY BE A CORRECT SOLUTION.

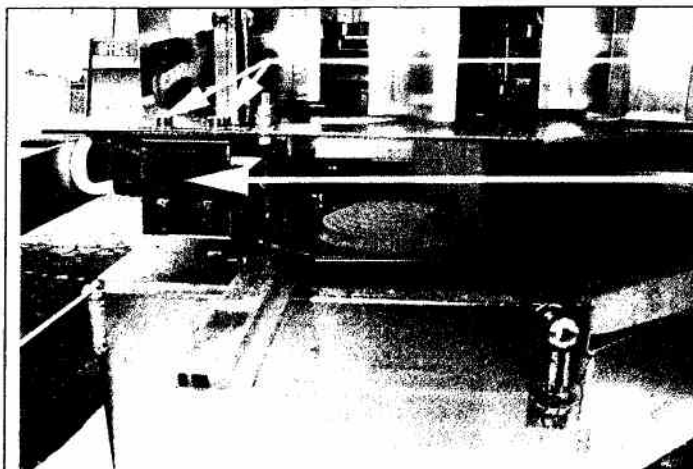

The micro switch is controlling the re-cocking function of the launcher, and is activated by the launching arm. To adjust the height of the switch, simply loosen the two slot mounted screws (shown) and slide the entire switch body up or down. Another adjustment, (not visible in this picture) is that the entire bracket may be moved in the slotted mounting holes at top of bracket, allowing the switch assembly to be moved left or right. NOTE, the ideal position as shown, with the launching arm parallel with the left side of the chassis and the leading edge of the arm flush with the tip of the switch lever.

## Adjustment of the back lash brake.

In order to eliminate vibrations, a brake band with a one-way clutch is installed on the launching arm shaft. Tightening of the adjusting bolt, turning clockwise, will increase the brake efficiency. Please adjust so that the launching arm stops without vibrations "on the corner of the chassis." If a moderate tightening of this bolt does not have the desired effect, the sprague within the band may be faulty or worn.

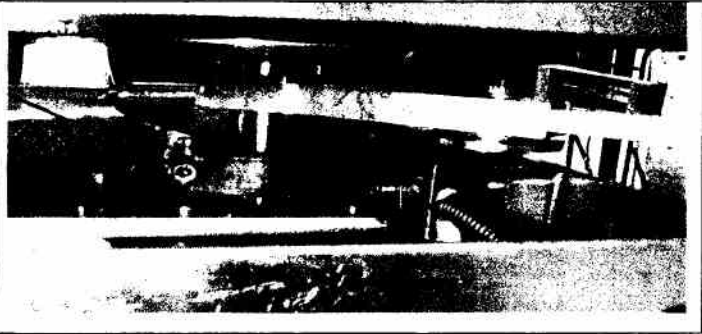

## Elevator clearance.

The only reason for the elevator to require an adjustment would be if there is a lot of broken targets loaded in the machine. The result is that the elevator must cut through the target pieces, which in turn may cause a slight bend in the parallel arm assembly, thus, necessitating adjustment. The machine itself will not break any targets unless it is severely out of adjustment. (under severe conditions it may be necessary to either straighten or replace the parallel arm assembly).

The elevator should be checked with the power shut off and the machine released manually, i.e. not by the electrical switch, since the elevator will be moving upwards immediately when released by the electrical switch.

The distance from the highest point of the elevator to the bottom rim of the target should be a minimum of a  $\frac{1}{4}$  inch, maximum about a  $\frac{1}{2}$  inch, as per illustration on the right.

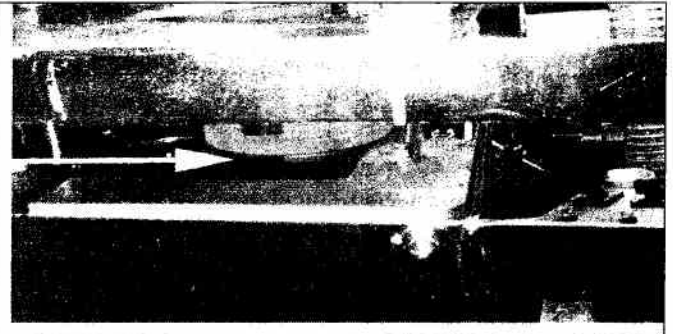

## Elevator height adjustment.

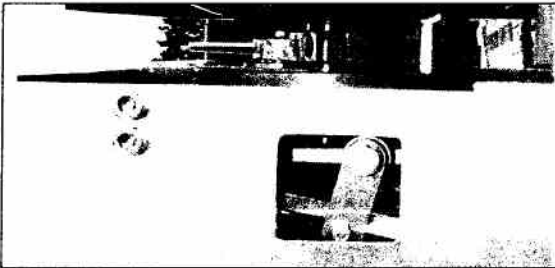

Adjustment of the elevator, is done by loosening the small bolt, as shown, at the bearing riser on the parallel arm assembly. Then by sliding the bearing riser for or aft you will be changing the height of the elevator. (Again, the machine must be released manually in order to have the elevator position correct).

And of course, as always, --- the power must be shut off and the launcher released before any adjustments are made.

## Target separating knife

A target separating knife is installed on your Beomat machine. The knife is installed in a reversed position for the reason that it must be adjusted individually for every manufacture of targets. When activated, loosen the nut at the top, reverse the knife and use the installed washers to adjust the height. It may be necessary to bend the knife slightly up or down in order to very precisely adjust the knife. The knife will perform excellently with wet targets, but bear in mind, if not adjusted properly it will cause more harm than good.

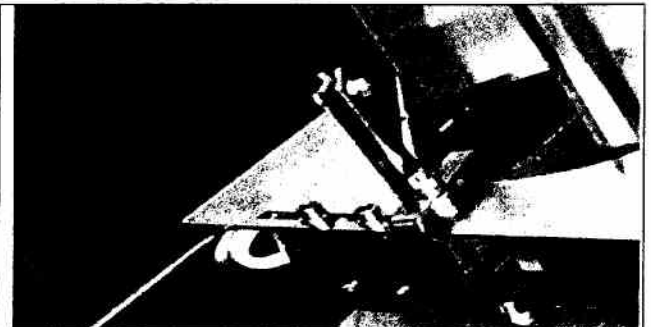



## Drive belt adjustment

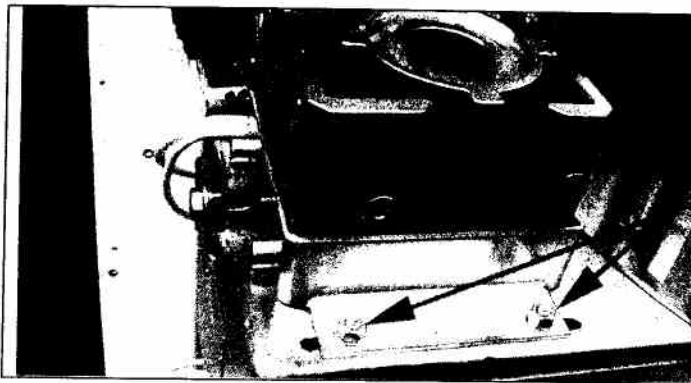

A pair of regular V-belts, are utilized between the reduction gear and the launcher main shaft. After some time, a year or two, it may be necessary to tighten the belts slightly. This is done by loosening the two fasteners as shown about one turn or at the most a turn and a half, then by tightening the belt tension bolt, shown, about one full turn. (It should be understood that too great a belt tension will put unnecessary pressure on the drive mechanism). Then re-tighten the two fasteners at the gear bracket.

## Leaf spring

A leaf spring is installed to provide an "ease down" of the target stack. Adjustment is normally not required, however, if the spring should need replacement, or come out of position, it should be adjusted so; that when the magazine is filled with targets and after delivering one target to the elevator, the full stack of targets will ease down as the magazine starts indexing again.

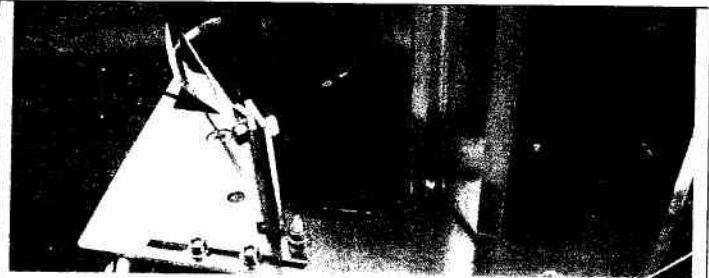

## Launching table fasteners

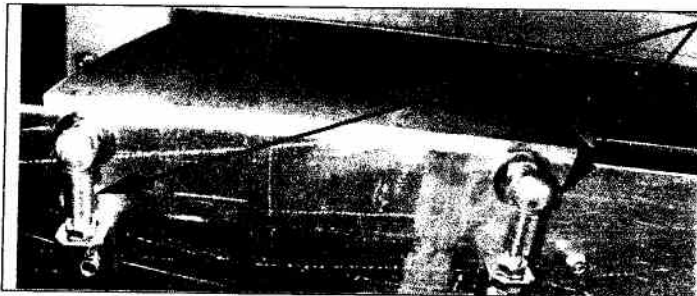

Never adjust the launching table fasteners. They have been adjusted once and for all. **ANY TAMPERING WITH, OR ADJUSTMENT OF THE SAME, WILL INVALIDATE YOUR WARRANTY.**

### INDEX

ADJUSTMENT GUIDE.....	4.
BACK LASH BRAKE ADJUST.....	6.
DRIVE BELT ADJUST.....	THIS PAGE.
ELECTRICAL CONNECTIONS.....	3.
ELEVATOR CLEARANCE / ADJUST.....	6.
LAUNCHING ARM ADJUST.....	5.
LEAF SPRING .....	THIS PAGE.
MICRO SWITCH ADJUST.....	5.
SKEET INSTALLATION.....	2.
SPRING TENSION, LENGTH OF THROW.....	3.
TARGET NEST.....	4.
TARGET SEPARATING KNIFE.....	6.
TARGET TRAJECTORY SETUP.....	3.
WARNING PAGE.....	1.

# Trap And Skeet Machines

Winchester by Laport • Due//Matic  
Beomat • Remington • Lincoln  
Sporting Clays Equipment

Repairing • Rebuilding  
Parts • Sales • Leasing  
25 YEARS EXPERIENCE

**Golden West Industries**

750 Arroyo Ave.  
San Fernando, CA 91340  
(818) 365-3946  
Outside of California  
1-800-548-5444  
FAX: (818) 365-8725

